

## Installation Instructions for 631402 to 631406 Master Cylinder Kit

**WARNING:** It is the responsibility of the person installing any brake component or kit to determine the suitability of the component or kit for that particular application. If you are not sure how to safely use this brake component or kit, you should not install or use it. Do not assume anything. Improperly installed or maintained brakes are dangerous. If you are not sure, get help or return the product. You may obtain additional information and technical support by calling JEGS. Use of JEGS technical support does not guarantee proper installation. You, or the person who does the installation must know how to properly use this product. It is not possible over the phone to understand or foresee all the issues that might arise in your installation. Racing equipment and brakes must be maintained and should be checked regularly for fatigue, damage, and wear.

**WARNING:** This component is designed for use in custom brake systems on performance, racing, and other special purpose built off-road vehicles. It is not intended as a direct replacement for any OEM application.

### Installation Instructions:

1. Prior to attaching the fluid lines, fill the reservoirs with fluid from a new, sealed container and purge any air from the master cylinder. Be sure the cylinder is level during the bleeding operation. If the cylinder is not level when mounted in the vehicle, you can perform this operation prior to attaching the master cylinder to its mount. Exercise care to not spill or spray brake fluid. Take all proper safety precautions including eye and skin protection and do not position your face directly above the reservoir. This process will assure a quick and effective full system bleed later.
2. Always mount the master cylinder to a secure, reinforced element of the chassis. There should be no movement or deflection at the mount point when brake pedal pressure is applied. When using fabricated mounts or pedal linkages, it is important that the alignment of the push rod and piston are kept as straight as possible to prevent side loading the piston against the master cylinder bore.
3. Be sure the pedal and push rod are adjusted to allow the master cylinder piston to fully retract against the snap ring at the back of the master cylinder bore when the pedal is fully retracted. There should also be adequate pedal travel to fully compress the master cylinder. Pedal return springs and stops are highly recommended.

### Plumbing Instructions:

1. Use an adjustable proportioning valve to set the front to rear brake bias.
2. Flare nuts to fabricate double flared 3/16" diameter brake lines are included with each master cylinder. Use only double flared lines. Do not attempt to use single flared connections. Standard automotive double flared lines with the correct size fittings can be purchased pre-made from JEGS.
3. Use of reinforced flexible lines should be limited to the connection between the fixed chassis and the moving suspension. All other lines along the fixed chassis should be hard steel lines.
4. Connect the primary outlet port "A" to the brakes at the end of the vehicle with the greatest total effective piston bore area. On most vehicles, this will be the front brake line.
5. Connect the secondary outlet port "B" to the brakes at the end of the vehicle with the lesser total effective piston bore area. On most vehicles, this will be the rear brake line.
6. On disc brake applications, where the fluid reservoir is mounted higher than the caliper bleeds, a residual pressure valve is usually not required.
7. On disc brake applications, where the fluid reservoir is mounted lower than the caliper bleeds, may require a 2 pound residual pressure valve to prevent fluid drain back and excessive pedal travel.
8. On drum brake applications, where the fluid reservoir is mounted lower than the drum bleeds, may require an inline 10 pound residual pressure valve JEGS #555-631031 (not included).
9. Once all fluid connections have been made, the complete system must be bled and checked for leaks prior to any test of the vehicle.

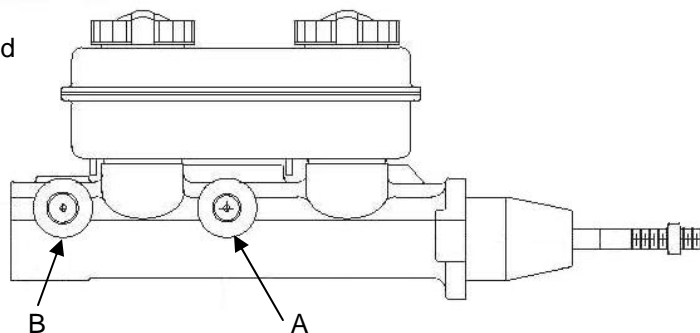

**WARNING TO ALL USERS:** Do not attempt to race or operate any vehicle without a full test and inspection of the brake system. Bleed the system and check all fluid connections for leaks. Test the brakes under controlled conditions. Make several stops in a safe area from low speeds and gradually work up to operating speeds. Always utilize safety restraint systems and all other appropriate or required safety equipment during testing.



1-800-345-4545 [jeps.com](http://jeps.com)